

Activity Booklet

Welcome to the Phi Foundation!

Here, you'll find the works of artists from all around the world. You will have fun looking at, creating and reflecting on what you see in the exhibition spaces.

In the little bag we've lent you, there are materials to help you complete the creative activities from this booklet. After your visit, you can bring back the bag at either of our two buildings' reception desks. You can keep the booklet and bring it home with you to continue the activities.

Enjoy your visit!

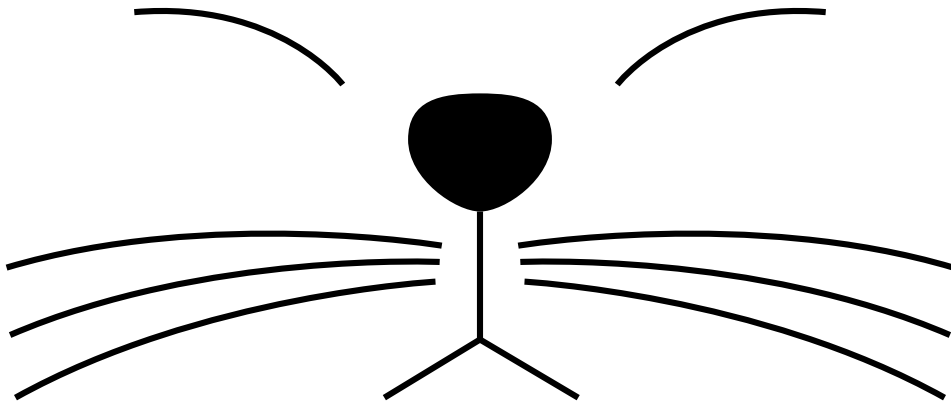

The Phi Foundation hosts contemporary art exhibitions where we can find artworks of all sorts.

What types of artworks can we see in an exhibition?

Usually, we can't touch the artworks that are in a museum, because some of them are very fragile. In that case, it is better to keep about one metre between you and the artwork. By doing so, you can see it clearly while making sure to avoid accidents, and you leave enough space for others to enjoy the artwork at the same time as you do.

However, some artists want people to touch their work. In that case, it will be clearly stated near the artwork. If you are not sure what the instructions are, you can always ask someone who works at the Foundation.

Right now, there are a lot of videos in our exhibitions. You can sit on a bench or on the floor to watch them, and you can stay as long as you wish! If you would like to say something while you are watching a video, make sure to speak softly.

If you have any questions about the artworks, ask a parent or an employee in the room. We will be happy to answer you!

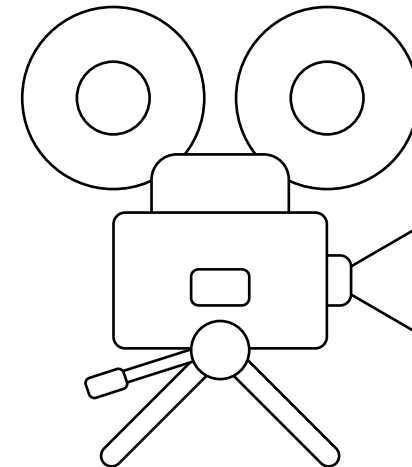

Today, you'll explore two very different exhibitions. At the 451 Saint-Jean Street building, we're exhibiting the work of Eva & Franco Mattes. Born in Italy, the Mattes now work in the United States. Their art questions the place of the Internet in our lives, and illustrates our relationship with technology.

At the 465 Saint-Jean Street building, you'll find the work of British artist Phil Collins. For his art, Phil likes to meet people to learn about what they enjoy doing. He collaborates with the people he meets to create videos and installations. He can then share with the world their interests, their perspectives and their questions.

451 Saint-Jean Street

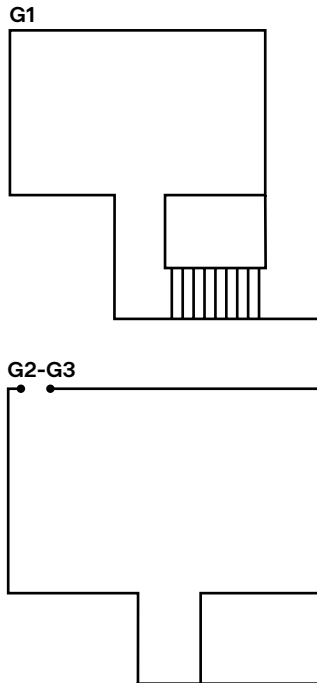

451 Saint-Jean Street

465 Saint-Jean Street

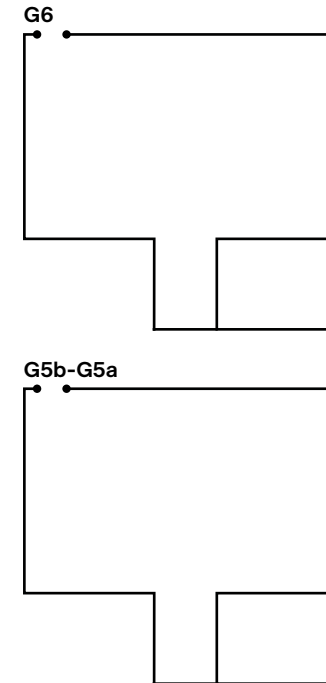

465 Saint-Jean Street

Create your very own sculpture inspired by an animal!

In the first room of Eva & Franco Mattes's exhibition, there is a sculpture representing a little cat in a very realistic way. Can you find it?

Look above your head.

The cat is hiding in one of the tiles of the gallery's ceiling!

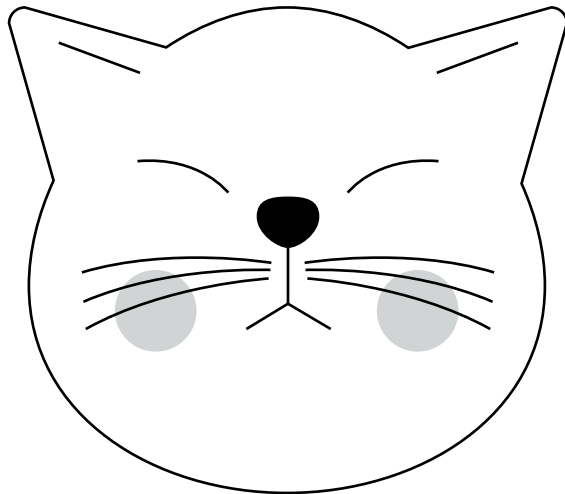

This gallery is filled with artworks. The exhibition's curator invites you to place a sculpture of an animal you choose, in a spot you also choose. Which animal would you pick? Would you prefer for your sculpture to be realistic, or made your way? Where would you like to put it in the room? You can draw it at the spot where you would like to exhibit it.

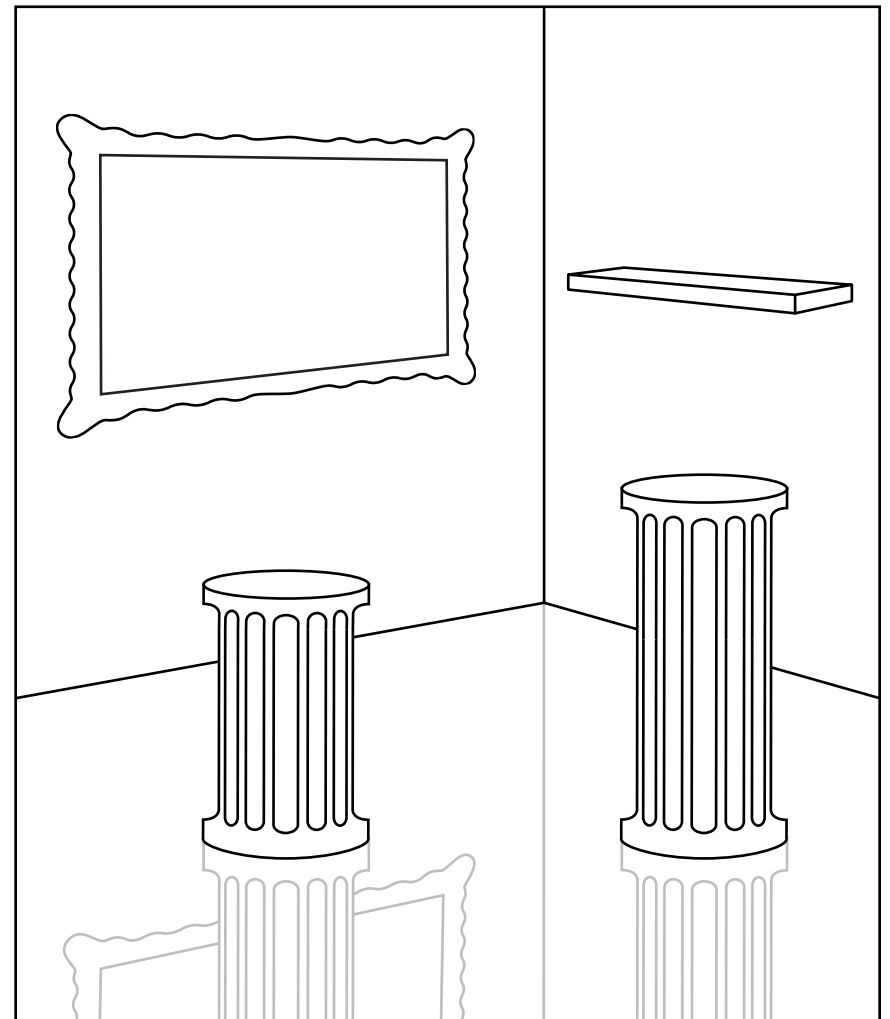

Make your own phone!

More and more, the structures used to send information from one place to another are invisible (or hidden). For example, when we send a text message to someone, do we see the message leave from the phone to get to another phone? Can we see what links these two phones?

For *Personal Photographs*, Eva and Franco wanted to create an artwork that would expose everything they shared during a certain period. The sculpture is made from cables that connect two servers together. These servers are continuously exchanging photographs, but we can't see any of the images - only the wires used to send the information from one place to another.

In the activity bag, you'll find small paper cups and some string. Did you know that with these three objects, you can create a system that will allow you to talk to someone even if they are very far away?

In the bag, we've added instructions to create a string phone. You can bring your phone home and try it in many different places!

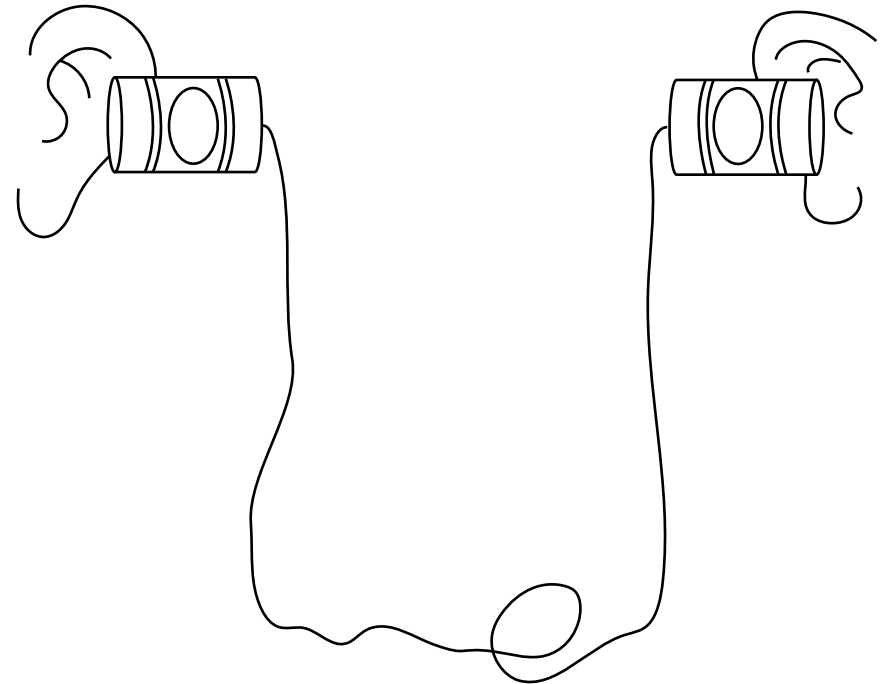

Activities continue in our other building at
465 Saint-Jean Street!

Compose a song!

In 2013, Phil Collins collaborated with Gulliver, an organization that helps the homeless population of the city of Cologne, Germany. There, he installed a free phone booth that everybody could use to call anyone, anywhere.

In exchange for the free phone calls, Phil informed everyone who used the phone that their conversations would be recorded, and that he would possibly use them as material for an artwork.

Phil selected some of the conversations he recorded and sent them to musicians from all around the world to transform them into new songs. When you walk into the listening booths, you will hear the result of this collaboration between Phil, the people who used the phone and the musicians.

Walk up to someone, and ask them to tell you the first sentence that comes to their mind. Try to remember the words (if you want, you can write them in the notebook).

Now, try to transform the sentence into a song. You can compose your own melody, or use one that you know well.

Perform the song you just composed!

To produce *the world won't listen*, Phil travelled to Bogota, Colombia, Istanbul, Turkey, and Jakarta, Indonesia. Upon arrival, Phil launched a campaign inviting these cities' residents to come and perform one of their favourite songs from the English band The Smiths, which is also one of Phil's favourite bands.

The three videos in this room present the three chapters of the project, filmed in all three cities!

Now that you've composed a song for activity 3, it's time to bring it to the stage! Would you like to sing this song in front of an audience? How would you decorate the stage? What would you wear?

Draw yourself on stage, with the setting you want!

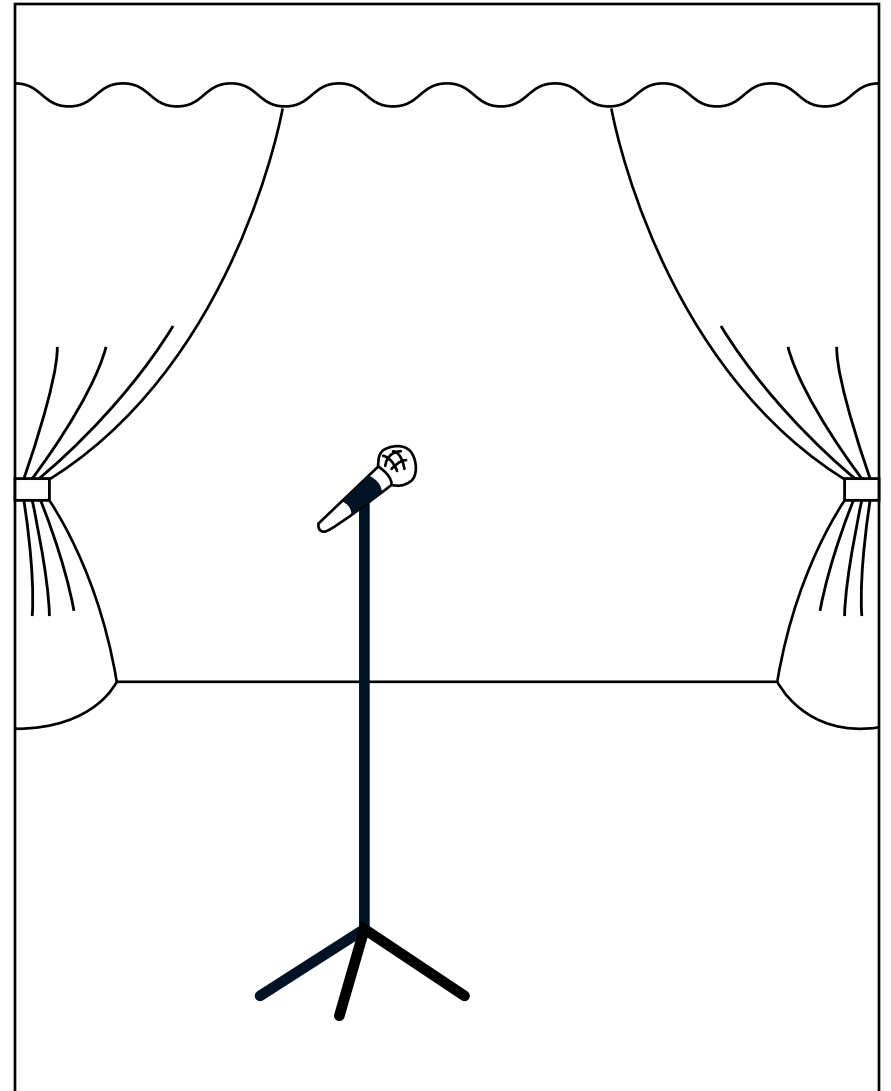

Transform your school for a night!

Bring Down The Walls is a video installation. What is a video installation? It is an artwork that includes videos, but also other items created by the artist and added to the room. This means that the artist imagined the video, but also decided what the space in which it would be presented would look like.

During the exhibition, Phil's installation will transform 4 times into two completely different things. For 4 afternoons, the installation will become a school, where participants will discuss the place held by prisons in our societies. For 4 evenings, the school will itself transform into a dance floor, and everybody will be invited to come and listen to music.

Imagine that your principal gives you the keys to the school and invites you to transform your classroom into whatever you wish for one day and one evening. What changes would you make? What would you remove or add? What subjects would you like to discuss that you don't usually talk about at your school? Who would you invite?

